

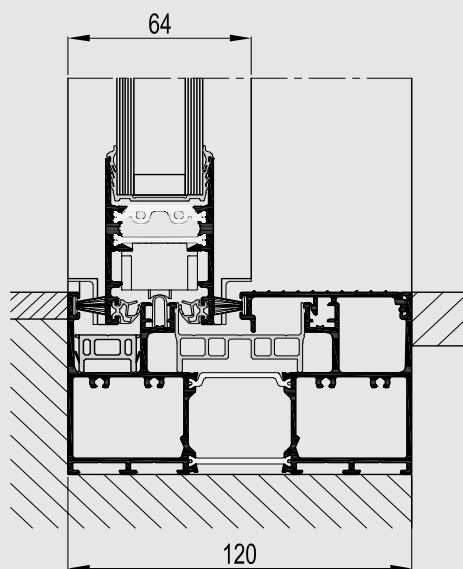

SlimPatio 68

Open Elegance



SlimPatio 68 is a highly insulated sliding system with ultra slim profiles and a concealed frame that combines comfort with elegance. Thanks to the clever design, this sliding window allows maximum natural light and provides optimal panoramic views. The integrated innovative technologies guarantee ultimate performance with regard to wind-, water tightness and thermal insulation, meeting the highest standards.





The sliding system SlimPatio 68 offers the design freedom required to create contemporary living spaces, combining ultimate brightness with maximum comfort.



FLEXIBILITY ABOVE ALL

This sliding system offers a wide range of opening possibilities, from elements which slide over 2- and 3-rail solutions, allowing you to open up to 6 leaves, to a single- and duo-rail pocket solution that allows you to slide the elements into the wall.

TECHNICAL CHARACTERISTICS			
Variants		2-RAIL	3-RAIL
Visible width	Built-in frame	68 mm	
	Vent	34 mm	
	Meeting section	34 mm	
Overall system depth	Frame	120 mm	176 mm
	Vent	64 mm	
Maximal vent height		2700 mm	
Maximal vent weight		250 kg	
Rebate height		18 mm	
Glass thickness		from 24 up to 36 mm	
Glazing method		with EPDM in accordance with the envelope principle	
Thermal insulation		32 mm and 36 mm fiberglass reinforced polyamide strips	

PERFORMANCES									
ENERGY									
	Thermal insulation ⁽¹⁾ EN ISO 10077-2	Uf-value down to 2.4 W/m ² K, depending on the frame/vent combination Uw-value down to 1.2 W/m ² K, for 3000mm x 2500mm frame/vent combination (Ug=0.8 W/m ² K)							
COMFORT									
	Acoustic performance ⁽²⁾ EN ISO 140-3; EN ISO 717-1	Rw (C; Ctr) = 40 (-2; 4) dB							
	Air tightness, max. test pressure ⁽³⁾ EN 12207	1 (150 Pa)	2 (300 Pa)	3 (600 Pa)	4 (600 Pa)				
	Water tightness ⁽⁴⁾ EN 12208	1B (0 Pa)	2B (50 Pa)	3B (100 Pa)	4B (150 Pa)	5B (200 Pa)	6B (250 Pa)	7B (300 Pa)	8A (450 Pa)
	Wind load resistance, max. test pressure ⁽⁵⁾ EN 12211; EN 12210	1 (400 Pa)	2 (800 Pa)	3 (1200 Pa)	4 (1600 Pa)	5 (2000 Pa)	Exxx (> 2000 Pa)		
	Wind load resistance to frontal deflection EN 12211; EN 12210	A (≤ 1/150)		B (≤ 1/200)		C (≤ 1/300)			

This table shows classes and values of performances, which can be achieved for specific configurations and opening types.

- (1) The Uf-value measures the heat flow. The lower the Uf-value, the better the thermal insulation of the frame.
- (2) The sound reduction index (Rw) measures the capacity of the sound reduction performance of the frame and glass.
- (3) The air tightness test measures the volume of air that would pass through a closed window at a certain air pressure.
- (4) The water tightness testing involves applying a uniform water spray at increasing air pressure until water penetrates the window.
- (5) The wind load resistance is a measure of the profile's structural strength and is tested by applying increasing levels of air pressure to simulate the wind force.

